

Specifications

Chuck Model	Spindle Nose	Collet Model	Accuracy Max Radial Runout	Collet Capacity	Collet Clamp Range	Chuck Stroke Linear	Max Draw Tube Force	Max Clamping Force	Max Speed	Chuck Weight
CB80-NX/A8	A2-8	80BZI	.0004"	3.250"	+/- .020"	.160"	11,240 lbs	25,853 lbs	5,500 rpm	37.7 lbs
			0.010mm	82.5mm	0.5mm	4mm	50 kN	115 kN		17.1 kg

Dimensions

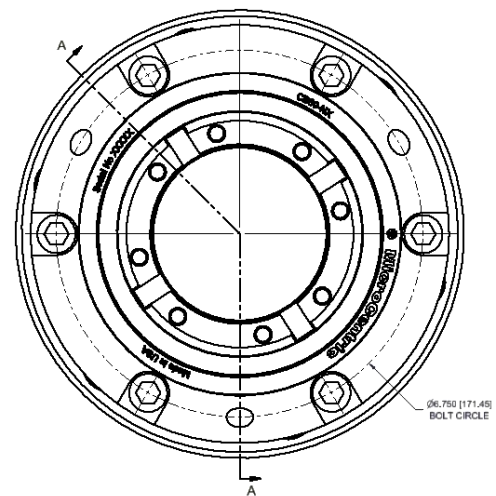
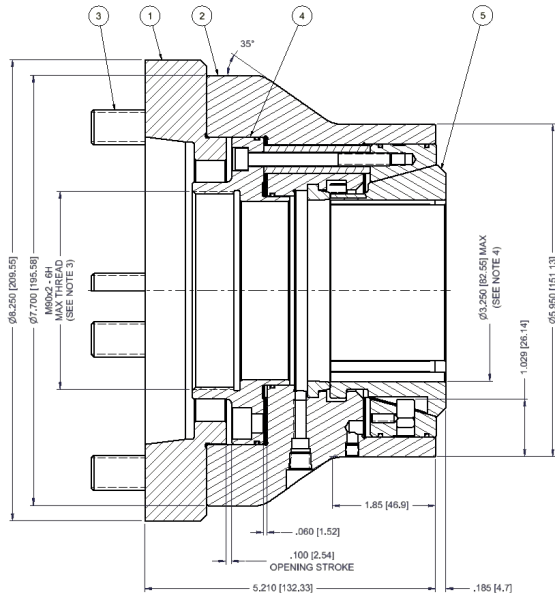

ITEM	QTY	PART NUMBER	DESCRIPTION
1	1	16 080 108	ADAPTER
2	1	16 080 200	FITTED BODY AND SLEEVE
3	6	83 196 M035	M16 x 35 SHCS
4	1	SEE NOTE 3	DRAW TUBE CONNECTOR
5	1	SEE NOTE 4	COLLET

NOTES

- DIMENSIONS SHOWN ARE FOR REFERENCE ONLY.
- THE CHUCK IS SHOWN IN THE NOMINAL CLAMPED POSITION.
- DRAW TUBE CONNECTOR AND THREAD PER CUSTOMER REQUIREMENTS.
- THE CHUCK IS SHOWN WITH THE MAX COLLET BORE.